

# Do Strong Export Relationships Imply Economic Dependency?

12-10-2018

Prashant Desai, U.S. International Trade Commission

Ross Hallren, U.S. International Trade Commission

Christine Kobza, U.S. International Trade Commission

## **Abstract**

Many analysts are concerned that countries where a large share of production is exported to a single country become economically dependent on that export partner and thus vulnerable to political influence. However, exercising this economic influence, for example via quotas on imports, is not costless. Using an Armington style CES industry specific model, we show that when a country imposes an import quota on final demand goods from a target country, the direct costs on the tariff originating country (i.e. the importing country) are relatively low and actually benefit domestic final demand good producers. However, when the quota imposing country places the quota on imports of intermediate inputs that are used to produce a final demand export good, the importing country internalizes costs that are similar in magnitude to those suffered by the target country.

This paper is the result of ongoing professional research of USITC Staff and are solely meant to represent the opinions and professional research of individual authors. This paper is not meant to represent in any way the views of the U.S. International Trade Commission or any of its individual Commissioners.

## 1. Introduction

We derive a vertically integrated industry specific partial equilibrium (PE) model to estimate, in a stylized way, the costs of exercising economic influence via quotas on both the subject and quota-enacting countries. By capturing vertical linkages in production, the model takes into account the global value chains nature of international trade and allows for direct feedback effects of imposing a quota on the importing country. As an interesting application, we consider the topic of economic influence. Many analysts are concerned that countries where a large share of production is exported to a single country become economically dependent on that export partner and thus vulnerable to political influence. However, our model predicts that exercising this economic influence via quotas is not costless.

We consider two scenarios: (1) the final demand country imposes an import quota on consumer goods from a target country and (2) a final demand good-producing country places a quota on imports of intermediate goods from a target country. The model predicts that restricting intermediate inputs is more costly than limiting final demand goods. This is because a quota on imported intermediate inputs generates a negative demand shock to domestic labor, capital, and other value added inputs. Consequently, quotas generate costs for multiple actors within the imposing country. By contrast, targeting final demand imports raises the costs of consumer goods, and thus reduces consumer welfare. However, such actions can, in the short-run, raise demand for domestic labor and capital.

The paper proceeds as follows. In section 2, we derive the World Bank 1-2-3 style, vertically integrated, industry specific model. In section 3, we discuss the experiments that we conduct to show the effect of quotas placed at two different locations in the supply chain. We then conduct a series of experiments and discuss the results in section 4. Section 6 concludes with a discussion of potential applications.

## 2. 1-2-3 Style Industry Specific Model

We start by deriving a version of the comparative static 1-2-3 model. Since our derivation closely follows Hosoe, *et al.* (2015) and Francois and Reinert (1997), we do not cover each step. The model assumes that final demand consumers maximize utility from consumption, producers are profit maximizers, markets are perfectly competitive, goods are differentiated by country of origin, country varieties are imperfect substitutes, all markets clear in equilibrium, and the zero-profit condition holds in equilibrium.

We consider two policy experiments. In the first experiment, the quota imposing country (S) puts a quota on final demand imports from a target country (T). In the second experiment, country (S) limits imports of intermediate inputs from a target country (T). S uses intermediate inputs to produce a final demand product for export to overseas final demand markets. To assess the impacts of the first policy shocks, we design a two tier version of the 1-2-3 model. However, the second experiment requires a three tier version. We describe the mathematics of each separately.

### 2.1. Model for Quotas on Final Demand Imports

Figure 1 illustrates the conceptual structure of our two-tier industry specific model for predicting the effects of applying a quota on final demand products. In this model, consumers in the quota imposing country (S), maximize a CES utility function for consuming final demand products from three country groups: the target country (T), the quota originating, or importing, country (S), and the rest of the world (ROW).

Given the Armington CES demand assumption, equation (1) represents the demand for the final goods variety  $j$ .

$$(1) q_{FD,j} = Q_{FD} b_{FD,j} \left( \frac{P_{FD}}{p_{FD,j}} \right)^{\sigma_{FD}} \quad \forall j \in \{T, S, ROW\}$$

The parameters  $b_j$  in equation (1) represent factors that shift the demand curves. When the model is calibrated, these parameters are set equal to the initial market share of each variety  $j$ .  $b_d$ ,  $b_{f,S}$ , and  $b_{f,n}$ , the market shares for the three varieties of products in the initial

equilibrium, sum to one.

The buyers' prices for each variety is  $p_j$ . The producer price for each foreign variety (S and ROW) is  $\frac{p_{FD,i}}{(1+\tau_{FD,i})}$ . The trade cost factor  $\tau_{FD,i}$  is equal to the ad valorem equivalent rate of the tariff and international transport costs on import variety  $i$ .

For simplicity, we assume that the supply functions for the S and ROW varieties of the FD goods are constant price elastic.

$$(2) q_{FD,i} = a_{FD,i} \left( \frac{p_{FD,i}}{1+\tau_{FD,i}} \right)^{\varepsilon_{FD,i}} \quad \forall i \in \{S, ROW\}$$

The parameters  $\varepsilon_{f,S}$ , and  $\varepsilon_{f,n}$  are constant price elasticities of supply, and  $a_{f,S}$ , and  $a_{f,n}$  represent factors that shift the supply curves. The equations for the supply curves assume a specific form (in this case, they are log-linear), and they are tailored to the industry by fitting the supply shift parameters to industry data. The calibrated values of the supply shifters reflect a variety of factors, including the level of production capacity and input costs.

By contrast, country T produces its output (Z) by combining value added (VA) and intermediate (INT) inputs via Cobb-Douglas production technology. Country T converts output into two distinct consumer varieties via Constant Elasticity of Transformation (CET) technology, one variety for the quota imposing country and one suitable for the rest of the world. Therefore, the supply functions for these two varieties are:

$$(3) q_{FD,i} = q_Z \delta_T \left( \frac{P_Z}{p_{FD,i}} \right)^{-\rho}$$

Here  $q_Z$  is the total production of the FD product by country T. The  $\delta$ 's represent the share of output (Z) dedicated to each market (S and ROW) in the initial equilibrium. They sum to 1.  $p_{FD,i}$  is the price of each variety of country T's output and  $P_Z$  is the producer price index of output. The parameter  $\rho$  is the constant elasticity of transformation and is the rate at which output can be converted between market varieties.

We assume that country T's output is insufficiently large relative to the ROW market to

change the world price. Consequently, we fix the world price by assuming that ROW demand is perfectly elastic.

Given the CES demand structure in the final goods market, the FD consumer price index is

$$(4) P_{FD} = \left[ \sum b_{FD,j} p_{FD,j}^{1-\sigma_{FD}} \right]^{\frac{1}{1-\sigma_{FD}}}$$

Total industry demand, itself, adjusts to changes in industry average prices. This reflects movement in consumption between industries. Here total demand in the industry,  $Q_{FD}$ , is

$$(5) Q_{FD} = k_A P_{FD}^\theta$$

The variable  $P_{FD}$  is a price index for the final demand product of the industry in the national market, and the parameter  $k_A$  represents the initial national aggregate industry expenditure ( $\bar{Y}_0$ ) at the baseline calibrated price,  $P_{FD} = 1$ . The parameter  $\theta$  is the price elasticity of total demand in the industry.

Country S's firms produce output ( $Z$ ) by combining value added and intermediate inputs via Cobb-Douglas technology. Given this assumption the factor demand functions for the two composite inputs (VA and INT) are

$$(6) q_i = \frac{\beta_i p_Z}{p_i} q_Z \quad \forall i \in \{INT, VA\}$$

Here  $\beta_{VA}$  and  $\beta_{INT}$  are the cost share parameters for the composite value added input and composite intermediate input, respectively, in the initial equilibrium. We assume constant returns to scale such that  $\beta_{VA} + \beta_{INT} = 1$ .

Given these demand equations and the zero profit condition, the price of the intermediate good is equal to its unit cost function.

$$(7) p_Z = \left( p_{VA}^{\beta_{VA}} \right) p_{INT}^{\beta_{INT}}$$

Country S profit maximizing firms combine labor and capital via Cobb-Douglas technology into the composite VA input. In our model, we assume that the supply of labor is perfectly elastic. (i.e. Firms can hire as many workers as demanded at the predominant wage ( $w$ )).

We assume that capital is fixed in quantity.

Country S's firms produce output using fixed expenditure shares of each value added input. That is domestic firms combine value added factors (F), labor (L) and capital (K) into an aggregate value added input (VA) via a Cobb-Douglas production function. The factor demand function for each value added input is

$$(8) \quad q_{VA,F} = \frac{\beta_F p_{VA}}{p_F} q_{VA}$$

Here  $p_F$  is the factor price for value added factor (F);  $p_{VA}$  is the price of the composite value added input, which is determined by the unit cost function; and  $\beta_F$  is the cost share parameter for the value added factor (F). We assume constant returns to scale such that  $\sum \beta_h = 1$ . Given the Cobb-Douglas technology, the unit cost function for the composite value added input is

$$(9) \quad p_{VA} = \prod_F (p_F)^{\beta_F}$$

Here  $\beta_F$  is the cost share of factor F. Given the perfect competition assumption, the unit cost function determines the price of the aggregate VA input in lieu of a supply curve.

Country S firms combine intermediate inputs from the different countries via CES technology into a composite intermediate input INT for production of the final demand product. The resulting demand function is

$$(10) \quad q_{INT,j} = q_{INT} b_{INT,j} \left( \frac{p_{INT}}{p_{INT,j}} \right)^{\sigma_{INT}} \quad \forall j \in \{T, S, ROW\}$$

The productivity parameters for the three varieties of products in the industry are  $b_{INT,d}$ ,  $b_{INT,f,s}$ , and  $b_{INT,f,n}$ . They are calibrated to the initial market shares for the three varieties of products in the industry and sum to one. The share for the composite foreign variety is  $b_{INT,f}$ .

The unit cost of the composite intermediate input is a CES price index. Given the perfect competition assumption, equation (3) determines the price of the composite intermediate input (INT) price in lieu of a supply function.

$$(11) \quad P_{INT} = \left[ \sum b_{INT,j} p_{INT,j}^{1-\sigma_{INT}} \right]^{\frac{1}{1-\sigma_{INT}}} \forall j \in \{T, S, ROW\}$$

The consumer prices for the three varieties of intermediate products are  $p_{INT,j}$ . The producer price of the domestic variety is the same as the consumer price. However, for the two foreign varieties (f), the producer prices are  $\frac{p_{INT,f}}{(1+\tau_{INT,f})}$ . The trade cost factor  $\tau_{INT,f}$  is equal to the ad valorem equivalent rate of the import tariff and international transport costs on imports for each variety (f).

Each variety of intermediate inputs (T, S, and ROW) are supplied via a constant price elasticity supply function:<sup>1</sup>

$$(12) \quad q_{INT,j} = a_{INT,j} \left( \frac{p_{INT,j}}{1+\tau_{INT,j}} \right)^{\varepsilon_{INT,j}}$$

The parameter  $\varepsilon_{INT,j}$  is the constant price elasticities of supply for each variety j, and  $a_{INT,j}$  represents factors that shift each supply curve. The equations for the supply curves assume a specific form (in this case, they are log-linear), and they are tailored to the industry by fitting the supply shift parameters to industry data. The calibrated values of the supply shifters reflect a variety of factors, including the level of production capacity and input costs.

We calibrate the model to the initial equilibrium conditions by setting all prices to 1 and adjusting the shift parameters in the demand equations to the initial FD and INT country variety market shares, setting the productivity terms equal to the cost shares in the VA factor demand equations, and equating shift parameters in the supply equations to the relevant initial quantities supplied.

## 2.2. Model for Quotas on Final Demand Imports

We present the conceptual model for our second experiment in figure 2. In our second experiment, country (S) imposes an import quota on intermediate inputs from country T at

---

<sup>1</sup> It is not difficult to extend the model to include imperfect competition, but in this case the producers have cost curves but not supply curves. The models in Khachaturian and Riker (2016) and Barbe, Chambers, Khachaturian and Riker (2017) include monopolistic competition, for example.

the most upstream level. Country S uses these intermediate inputs to produce output (Z) that is exported either to a third FD demand country C or to the rest of the world (ROW). The model structure is as in the previous section, except that we extend the length of the supply chain to explicitly include the production chain for the intermediate input from country T that is used to produce S's export output. Consequently, the mathematics are identical to those in the previous section, though we increase the number of equations and expand the indices for clarity.<sup>2</sup> This model is calibrated identically to the previous model. The main difference between these two models is the location of the policy shock.

### 3. Experiments

We conduct two experiments. In experiment 1, country S imposes a quota that restricts imports of country T's final demand variety to 10% of its initial equilibrium quantity. In the second experiment, country S imposes the same quota on imports from country T. However, in the second experiment, country S is not the final demand country. In this experiment, country S imports intermediate goods from country T that it then uses to produce a final demand good that is, in part, consumed by a third country outside of S.

Each time we run the model, we set the market shares at the FD and INT levels and the share of output (Z) that is exported the FD brand. We then draw the CES elasticities and the CET elasticity from three identical uniform distributions with a lower bound of 2 and an upper bound of 10.<sup>3</sup> We shock the model, estimate the percent changes in prices and quantities, and store the results.

In experiment 1, we allow the market share of variety T in country S's final demand market to vary between 10 and 90%; we allow T's market share in T's intermediate input market to range between 10 and 90%; and we allow the share of final demand output (Z) exported to country S to fall between 10 and 90%. When we adjust a market share, we increase it by

---

<sup>2</sup> A full derivation for both models is available in a separate appendix on request.

<sup>3</sup> This is the meaningful qualitative range of the Armington elasticities. (Francois & Hall, 1997) Additionally, this range encompasses the range of estimated Armington elasticities. (Gallaway, *et al.*, 2003; Feenstra, *et al.*, 2018)



10 percentage points. Consequently, there are 729 permutations.<sup>4</sup> For each permutation, we run the experiment 100 times, each time we draw a new set of elasticities. Therefore, we conduct experiment 1 72,900 times.

In experiment 2, we allow the market share of variety S in the final demand market to vary between 10 and 90%; we allow T's market share in S's intermediate input market to range between 10 and 90%; and we allow the share of S's final demand output (Z) exported to the third country (C) final demand market to fall between 10 and 90%. As before, when we adjust a market share, we increase it by 10 percentage points. Consequently, there are 729 permutations. For each permutation, we run the experiment 100 times, each time we draw a new set of elasticities. Therefore, we conduct experiment 2 72,900 times.

In all experiments, we assume that the initial market size of the final demand goods market is \$100. Additionally, we assume that the industry price elasticity of demand is -1. In this framework, industry demand responds proportionally to changes in the final demand CPI.

## **4. Results**

### **4.1. Cost to Importing Country of Imposing FD Quota**

When the country (S) imposes the quota on FD imports from country T, the costs fall on country S consumers in the form of higher prices, which results in a decline in overall quantity demanded in the FD goods market. However, country S firms, by contrast, enjoy increased real sales that more than off-set the overall decline in market demand.

In figure 3, we graph the effects of the policy on the percent change in the price of country S's FD variety, the percent change in demand for variety S, and the overall change in FD industry quantity demanded. Here we summarize the results over the range of country T's initial market share, holding T's initial market share in the INT market and share of T's output exported to country S fixed at 50% and 20%, respectively. We do this for expositional simplicity because the results are insensitive to the initial value of these two share parameters.

---

<sup>4</sup>  $9*9*9 = 729$ .

In this figure, we see that the effect of the policy shock grows non-linearly with the magnitude of country T's initial market share. This is unsurprising when we consider the ad-valorem tariff equivalent (AVE) of the import quota.<sup>5</sup> As the initial market share of T increases from 10% to 90%, the AVE of the quota nearly triples. The AVE is approximately 67% when T's initial market share is 10% but rises to 159% when T's market share is 90%.

Also, we see that the variance of the effect on any outcome increases dramatically as we increase the initial market share of T. This illustrates that the effect of this policy shock is sensitive to the assumed Armington elasticities; and therefore, we would expect to see variance in the effect of this shock across industry. Despite the wide variance, the results are qualitative consistent: the results always have the same sign across all market shares and are monotonically increasing.

In table 1, we summarize the mean outcomes for the four variables of interest, percent change in quantity demanded for S, percent change in the price of S, percent change in industry demand, and percent change in the industry CPI, by T's initial market share. Consumers experience only slightly higher prices for variety S for all initial market shares. However, the CPI rises by approximately an order of magnitude more than the increase in the price of S. For all initial market shares, overall industry real demand declines. However, country S's firms increase quantity sold by the overall decline in demand. Consequently, we see that when country S imposes the quota at the final demand level it is consumers who bear the costs of exercising economic influence on country T.

## **4.2. Cost to Importing Country of Imposing INT Quota**

Now we assume that country S imposes an import quota on country T at the intermediate goods level. Because the shock occurs at a more upstream level, we summarize the results across all initial market share parameters. However, the qualitative results are in some ways similar to the previous experiment: country S intermediate good producing firms gain market share due to the import quota. However, because the quota raises the price of

---

<sup>5</sup> We assume that, in the context of this model, any quota can be represented by an ad valorem equivalent tariff in so far as for any tariff there is an ad-valorem tariff that will have equivalent effects on trade. We are not concerned with differences in the amount of tariff revenues, or quota rents, collected.

intermediate inputs, demand for country S's output declines. Therefore, demand for labor and capital fall, reducing employment and the rate of return on capital, respectively. The magnitude of these effects is positively correlated with the initial market share of country T's variety in the intermediate goods market.

The AVE of the quota on country T intermediate inputs ranges from 66% when country T's INT market share is 10% to 121% when the same market share is 90%. The AVE is about 85% with little variance when we cycle over the range of the other market share parameters. Therefore, as before, we expect the magnitude of this shock to be positively correlated with the size of country T's initial market share in country S' intermediate goods market.

Figure 4 summarize the effect of the quota on quantity demanded for variety S' intermediate goods. We allow each of the three market share parameters to vary individually in each panel of figure 4, holding the other two fixed. Given that the AVE of the quota primarily varies with the size of country T's initial INT market share, it is unsurprising that the increase in quantity demanded for country S' INT variety primarily responds to changes in country T's initial market share. Demand for INT variety S increases by approximately 6.6% at the mean when T's market share is 10% and by 331% at the mean when T's market share is 90%.

Figure 5 shows that as demand shifts away from variety T to variety S, the price of variety S rises. However, the rise is modest and is primarily driven by changes in the initial market share of T in INT. On average, the percent change in price ranges from .2% and 4.8%, as T's share in INT increases from 10% to 90%.

The price effect of the import quota passes through the supply chain downstream to country S's output (Z) and its exports to the foreign final demand goods market. The policy shock on variety T's intermediate inputs causes the price of country S's output to increase by, on average, 1% and 18%, depending on T's initial market share in INT. Additionally, the import quota causes prices for the importing country's final demand product to rise, on average, by .5% when T's INT market share is 10% and by 10% when T's INT market share is 90%. (see table 2)

The response to the rise in price of country S's FD product is a decline in quantity demanded for this variety. On average, depending on country T's initial INT market share, quantity demanded for variety S's FD product falls by 1.4% and 26%. Moreover, demand for country S's output (Z) falls by 2.6% and 40%, on average.

The decline in demand for the quota imposing country's output (Z) causes demand for the aggregate intermediate input INT fall by, on average, 4.3% when T's initial INT market share is 10% and 56% when T's market share is 90%. Note that the decline in overall quantity demanded for intermediate inputs INT is less than the increase in quantity sold by country S's intermediate input producers. Therefore, as in experiment 1, the sanction increases the real output by domestic, country S, firms.

However, the decline in demand for country S's output also reduces overall quantity demanded for value added inputs (VA). Demand falls by 1%, on average, at the low end and 17%, on average, at the upper end as T's share in the INT market ranges from 10% to 90%. As a consequence of this negative demand shock, the model predicts that employment will fall, on average, by 2% when T's INT share is 10% and by 30% when T's share is 90%.

Figure 6 shows how labor responds to the decline in demand for country S's output across the range of market shares. As without other outcomes of interest, the percent change in labor increases in magnitude as we increase the initial share of T in INT. This is unsurprising because the AVE of the quota on imports of T's intermediate inputs increases the larger T's initial market share in INT. Since the labor supply is assumed to be perfectly elastic, the negative demand shocks reduces the number of workers employed but not the wages of those employed.

Capital is assumed to be fixed in supply so any decline in demand for capital translates into only a reduction in the price of capital. As with labor, the price of capital responds primarily to increases in the AVE of the policy shock. As the AVE increases, the magnitude of the decline in the price of capital also increases. The average decline in price of capital ranges from 2% and 30%. (see figure 7)

The model predicts for a wide range of cases and parameterizations that the quota on

imports of intermediate inputs increases demand for the importing country's intermediate inputs. However, the cost of the quota is borne by workers, through decreased employment, and capital owners, in the form of lower rates of return to capital.

### **4.3. Cost on Target Country**

Because of the mathematical symmetry between levels of the Armington model, the effect of the quota on the target country (T) is identical regardless of whether the quota is applied on FD or INT imports from country T. For simplicity we present the results when a quota is placed on T's final demand exports to country S.

Overall, we see that while the AVE of the quota is larger, the larger is the share of T in the country S's final demand goods market, the effect of the quota on T is primarily driven by the share of country T's output (Z) that is dedicated to producing goods for the importing country. Put simply, the effect of the quota on T is almost entirely determined by the share of T's output that is exposed to the quota. The larger the share is, the larger the effect is.

We summarize the results in table 3 and separate the average result by the share of T's output that is dedicated to producing final demand goods for the quota originating country. The effect of the quota on output (Z) ranges from 3% to 49%. As figure 8 shows, the magnitude of the demand shock is primarily a function of the percentage of output that is dedicated to the quota'ed market. This negative demand shock reduces demand for value added and intermediate inputs. Employment falls by as much as 60% and as little as 4%. The model predicts that the price of capital falls by between 4 and 60%. Demand for T's intermediate goods input drops by between 3 and 52%.

## 5. Conclusions and Areas for Future Research

We derive an industry specific, vertically integrated CES Armington model to estimate the economic costs of imposing an import quota applied at two different points in the supply chain. We isolate and quantify both the direct effect of the quotas on the target country and the indirect, feedback, effects on the importing country. We show that when a quota imposing country places an import quota on final demand goods from a target country, the importing country's final demand goods producers gain market share and the burden falls on the tariff originating country consumers in the form of higher prices. The target country sees a reduction in employment, a decline in the price of capital, and a negative shock to demand for output, and intermediate inputs. However, when the importing country imposes the quota on imports of intermediate inputs that are used to produce a final demand export good, the importing country internalizes costs that are similar in magnitude to those suffered by the target country.

This result are qualitative insensitive to market share and elasticity parameterizations. The cost of the quota on the importing country is always greater in magnitude, the greater is the initial market share of the target country in the market subject to the quota. This result is intuitive when we consider that the AVE of the import quota is always larger, the larger the target country's initial market share. Additionally, the variance of the results grows as we increase the AVE of the quota.

For the target country, the costs are primarily a function of the share of output that is dedicated to the importing country in the initial equilibrium. The more exposed T's output is to the shock, the larger the effect of quota is on T.

Because we use a static, industry specific model, our results do not reflect the long-term adjustments of the global economy to the analyzed quotas. However, the model gives a structured method for predicting the costs of quotas in the short to medium-term and analyzing their distribution across economic agents. We conclude from our analysis that target countries are more vulnerable to quotas from countries to which they export a larger percentage of their output of a final demand good because these importing countries can

enact quotas at low direct cost. Target countries are much less vulnerable to quotas from countries to which they send intermediate inputs used to produce final demand goods for export.

This result echoes the insights from the cumulative tariffs literature that even small tariffs accumulate and cascade in vertically integrated production chains. In some cases, the cumulative tariff in the downstream sector is up to three times larger than the initial upstream tariff. (Miroudot and Rouzet, 2013; USITC, 2017) These tariff accumulation effects can be so large that domestic downstream producers will petition government for economic relief to offset the cost of temporary trade barriers on imported upstream inputs. (Erbahar and Zi, 2017) This literature underscores the point that trade barriers, tariffs or quotas, on imported intermediate inputs can generate large costs to domestic exporters.

While the goal of our paper is to derive and introduce a vertically integrated, industry specific model, it may have useful application in the analysis of economic sanctions. There is an extensive applied literature on economic sanctions that may benefit from a structural modeling framework like the one developed in this paper.

Many policy makers have expressed concern that strong export relationships necessarily imply economic dependency and vulnerability to exploitation by the importer. The precise costs caused by negative import shocks can depend on the degree of import- and export-reliance between the target and importing country (Dashti-Gibson, *et al.*, 1997).

Causing concern for some policymakers is China's ability to exploit strong trading relationships to extract political concessions. Several recent examples include recent political conflicts over the South Korean THAAD system, Taiwanese political elections, and Norwegian Nobel Peace Prize recipients. (Hancock and Wang, 2017; Mayger and Lee, 2017; Mullen, 2017; Meick and Salidjanova, 2017) The costs for "target" states are well-documented: trade actions affect a range of outcomes, from income inequality and healthcare spending to foreign direct investment (Biglaiser and Letzkian, 2011; Allen and Letzkian, 2013; and Afesorgbor and Mahadevan, 2016).

Not as well researched are the significant costs to "sender" countries of imposing trade

restrictions. Economic sanctions, though generally motivated by political concerns, are quite similar to traditional protectionist measures in terms of their direct effects on sender countries (Farmer, 2000). Embargoes and quotas can directly impact the sender country's labor force, consumers, and global competitive standing, even before considering the effects of retaliatory measures from the target state. Using simple general equilibrium models, Frankel (1982), Irwin (2005), and O'Rourke (2007) find that the U.S. Embargo Act of 1807, and the resulting retaliatory actions, reduced U.S. consumer welfare by 4-8% of GDP, via reduced trade and higher import prices.

A few empirical studies employ a gravity model framework to estimate the effect of sanctions on the originating country. Using data from 1980 – 2000, Yang, *et al.* (2004) find that US economic sanctions against China did not significantly reduce trade with China but did raise import prices. However, export controls may have contributed to up to a million fewer jobs in 2000. Additionally, these controls allowed US competitors in high-tech industries, such as the nuclear power industry, to gain a competitive advantage and increase their exports to China.

Similarly, in a 2016 working paper, Crozet and Hinz use monthly trade data and a gravity framework to assess the effect of 2014 sanctions and counter-sanctions on and by Russia on exports from originating target countries. They estimate global trade was \$4.7 billion per month lower than the counterfactual no sanctions case. Interestingly, they find that 91% of lost trade occurs through non-embargoed products.

Additionally, the costs of enacting export quotas can be indirect and persist long after they have been lifted. Hufbauer, *et al.* (1997) and Hufbauer, *et al.* (2007) suggest that such export restrictions may create credibility issues for firms in the origin country, as they can be perceived as unreliable suppliers. For example, subject country firms have responded to restrictive trade shocks by designing sanctioning country goods and technology out of their final products to hedge against future restrictions. (Kwon, *et al.*, 2017)

For many years, Japan received over 90% of its rare earth imports from China. However, after the Senkaku Islands disputes in 2010 and 2012 in which China cut off its rare earth exports to Japan, the Japanese chose to source these inputs elsewhere to ameliorate the



China country risk. Specifically, Japan cooperated with India, Vietnam, and Australia to develop and source rare-earth mines. Taiwan has gone so far as to develop the New Southbound Policies to expand cooperation with other Asian countries and explicitly reduce dependence on China. These types of responses to economic coercion illustrate the costs that quota imposing countries can incur and the long-term consequences they may face. (Glaser, *et al.*, 2018 ; Kwon, *et al.*, 2017)

## Bibliography

- Afesorgbor, Sylvanus Kwaku, and Renuka Mahadevan (2016), "The Impact of Economic Sanctions on Income Inequality of Target States," *World Development*, vol. 83.
- Allen, Susan Hannah, and David J Lektzian (2013), "Economic Sanctions," *Journal of Peace Research*, vol. 50, no. 1.
- Biglaiser, Glen, and David Lektzian (2011), "The Effect of Sanctions on U.S. Foreign Direct Investment," *International Organization*, vol. 65, no. 03, 2011.
- Crozet, Matthieu and Julian Hinz (2016), "Friendly fire – the trade impact of the Russian sanctions and counter-sanctions," Keil Working Paper, No. 2059, Kiel Institute for the World Economy (IfW).
- Dashti-Gibson, Jaleh, et al. (1997), "On the Determinants of the Success of Economic Sanctions: An Empirical Analysis," *American Journal of Political Science*, vol. 41, no. 2.
- Erbahar, Aksel and Yuan Zi (2017), "Cascading trade protection: Evidence from the US," *Journal of International Economics*, 108: 274 – 299.
- Farmer, R. D. (2000), "Costs of Economic Sanctions to the Sender," *The World Economy*, 23(1), 93-117.
- Feenstra, Robert C., et al. (2018), "In Search of the Armington Elasticity." *The Review of Economics and Statistics*, vol. 100, no. 1, 2018, pp. 135–150.
- Francois, Joseph F. and Hall, H. Keith (1997), "Partial Equilibrium Modeling," In *Applied Methods for Trade Policy Analysis*, edited by Francois, Joseph F. and Reinert, Kenneth P. Cambridge University Press, Cambridge.
- Frankel, J. A. (1982), "The 1807–1809 Embargo Against Great Britain," *The Journal of Economic History*, 42(02), 291–308.
- Gallaway, Michael P, et al. (2003), "Short-Run and Long-Run Industry-Level Estimates of U.S. Armington Elasticities." *The North American Journal of Economics and Finance*, vol. 14, no. 1, pp. 49–68.
- Glaser, Bonnie S., et al. (2018), "The New Southbound Policy," CSIS, Center for Strategic and International Studies (CSIS).
- Hancock, Tom, and Xueqiao Wang (2017), "South Korean Consumer Groups Bear Brunt of China's Thaad Ire," *Financial Times*, Financial Times, 20 Aug. 2017.
- Hosoe, Nobuhiro, Kenji Gasawa, and Hideo Hashimoto (2015), *Textbook of Computable*

*General Equilibrium Modeling: Programming and Simulations*, Palgrave Macmillan.

Hufbauer, Gary Clyde, et al. (1997), "US Economic Sanctions: Their Impact on Trade, Jobs, and Wages." Peterson Institute for International Economics (PIIE).

Hufbauer, Gary Clyde, et al. (2007), *Economic Sanctions Reconsidered* (3rd ed.), Peterson Institute for International Economics (PIIE).

Irwin, D. A. (2005), "The Welfare Cost of Autarky: Evidence from the Jeffersonian Trade Embargo, 1807-09," *Review of International Economics* 13(4), 631-645.

Keller, Wouter J., "A Nested CES-Type Utility Function and its Demand and Price-Index Functions," *European Economic Review* 7(1976): 175-186.

Kwon, Tae Young, et al. (2017), "The Effect of THAAD on Korean Consumers and Distributors," *Journal of Marketing Thought*, 4(3): 49-65.

Mayger, James, and Jiyeun Lee (2017), "China's Missile Sanctions Are Taking A Heavy Toll on Both Koreas," *Bloomberg.com*, Bloomberg, 30 Aug. 2017.

Meick, E., & Salidjanova, N. (2017), "China's Response to U.S.-South Korean Missile Defense System Deployment and its Implications," U.S.-China Economic and Security Review Commission.

Mullen, Jethro (2017), "China Can Squeeze Its Neighbors When It Wants. Ask South Korea," *CNNMoney*, Cable News Network, 30 Aug. 2017.

O'Rourke, K. H. (2007), "War and welfare: Britain, France, and the United States 1807-14," *Oxford Economic Papers*, 59.

Rouzet, Dorothée, and Sébastien Miroudot. "The Cumulative Impact of Trade Barriers along the Value Chain: An Empirical Assessment Using the OECD Inter-Country Input-Output Model." Presented at the 16th Annual Conference on Global Economic Analysis in Shanghai, China in 2013.

United States, U.S. International Trade Commission (USITC), "The Economic Effects of Significant U.S. Import Restraints Ninth Update 2017," USITC, 2017.

Yang, Jiawen, et al. "US Economic Sanctions Against China: Who Gets Hurt?" *World Economy*, vol. 27, no. 7, 2004, pp. 1047-1081.

Figure 1. Import Sanction on FD Goods

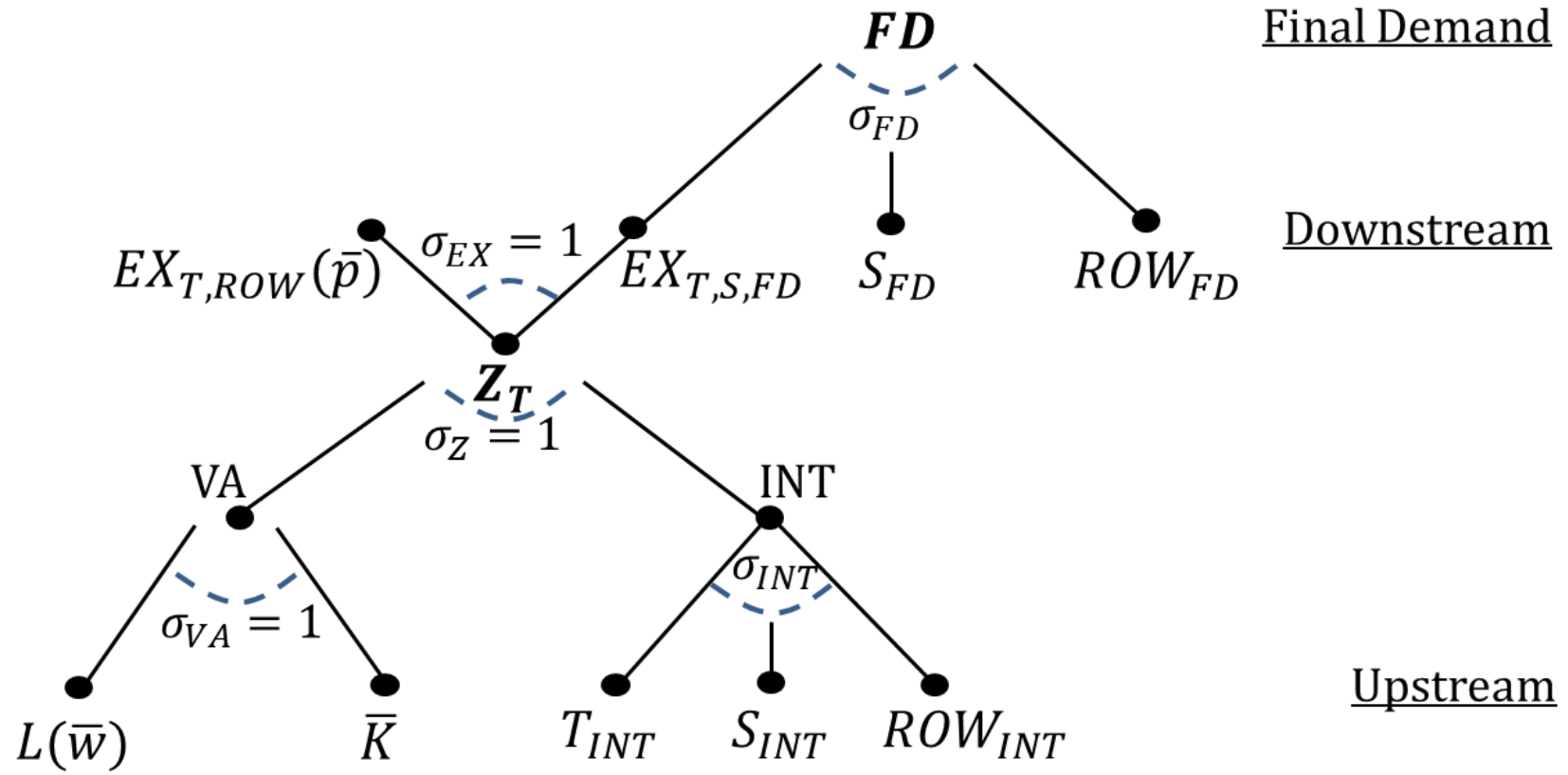
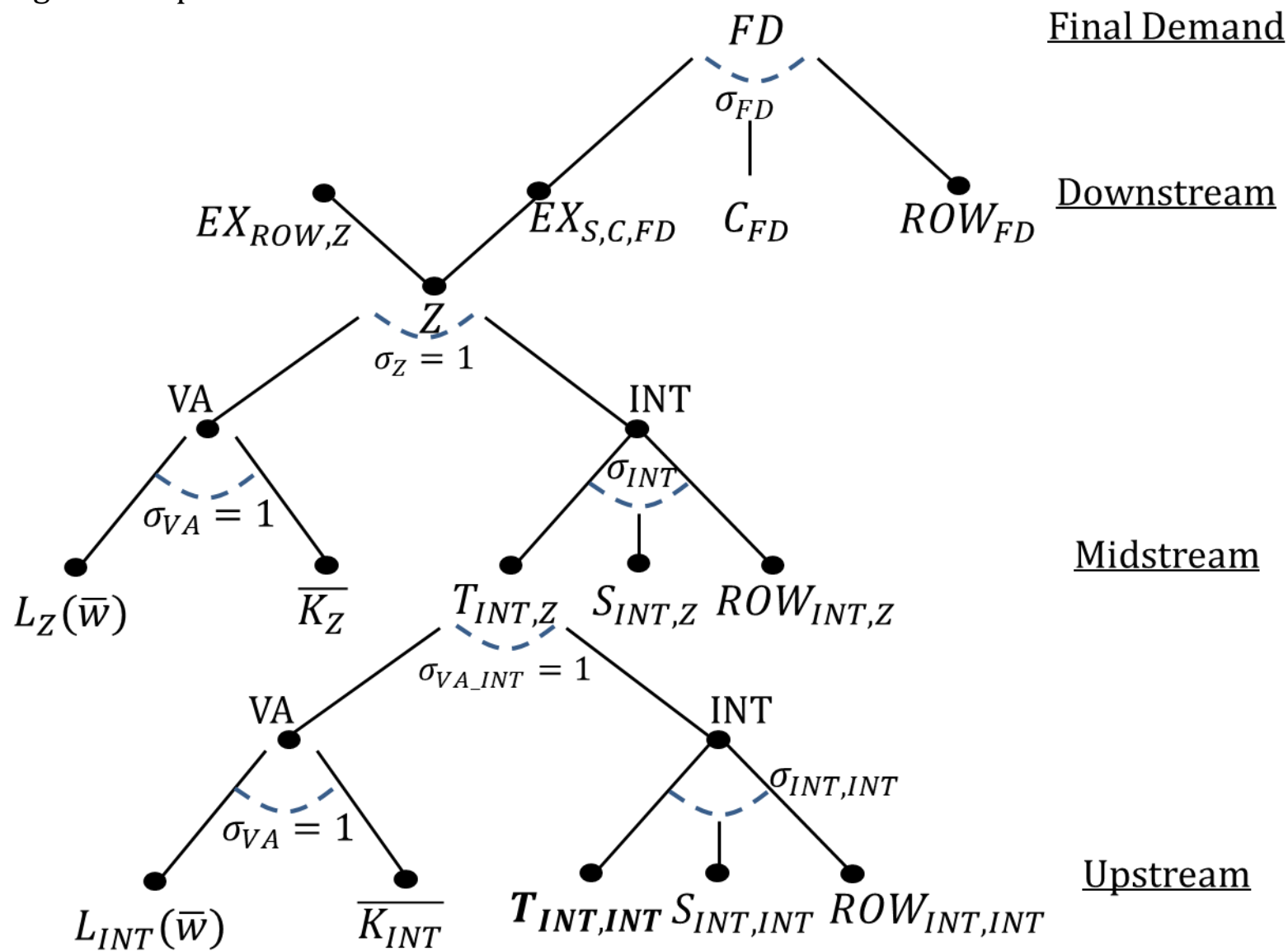

Figure 2. Import Sanction on INT Goods



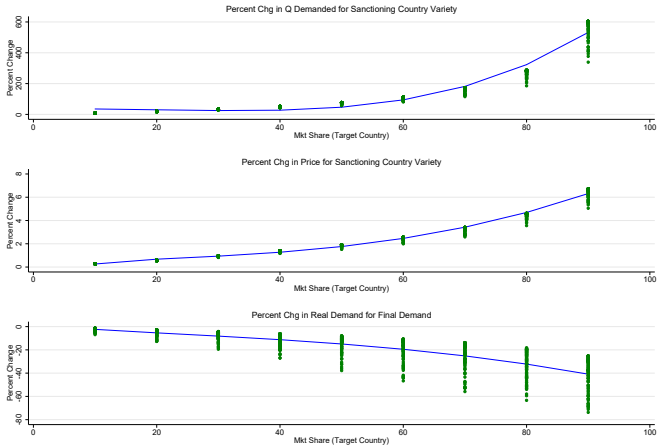

Figure 3

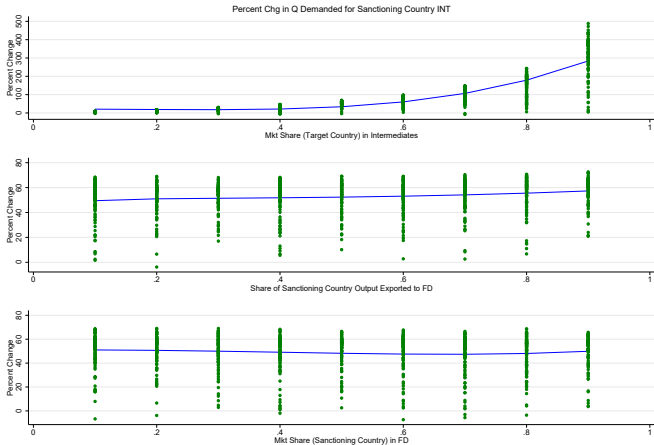

Figure 4

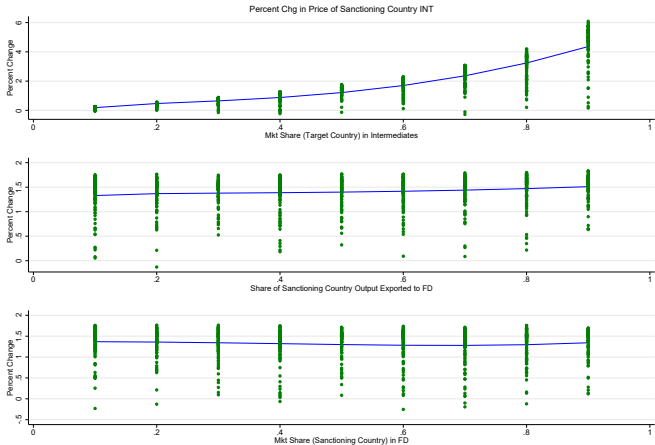

Figure 5



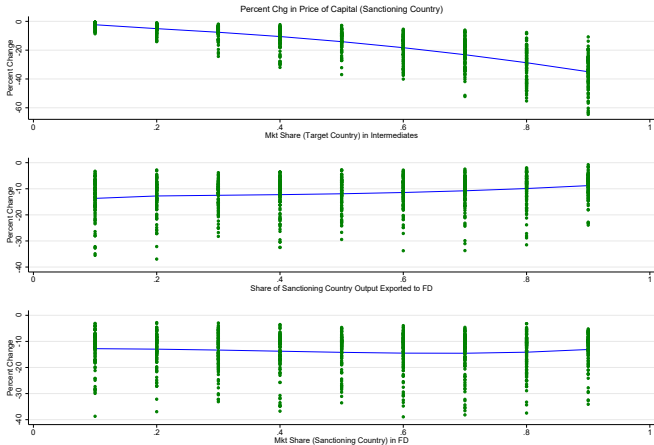

Figure 6

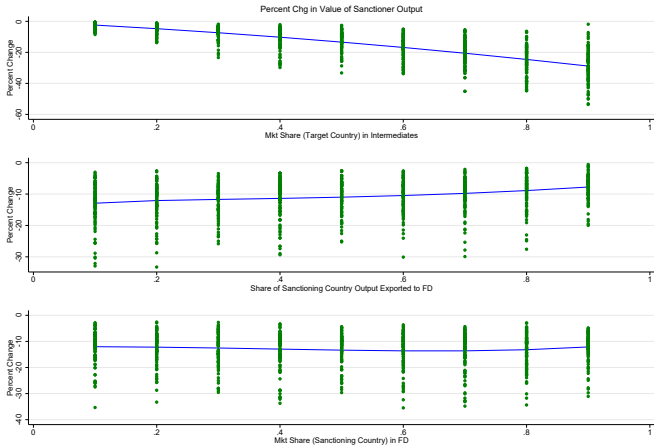

Figure 7

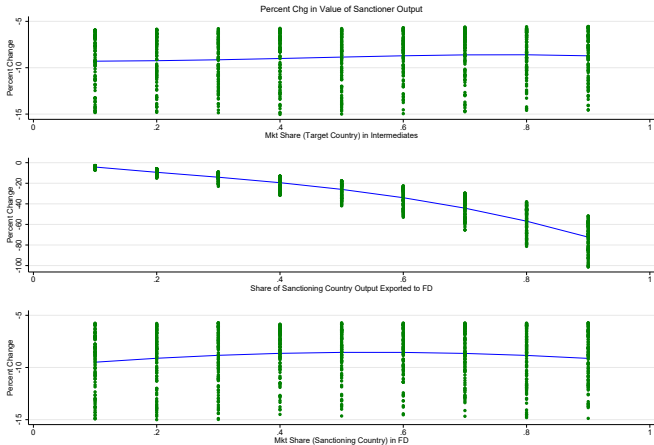

Figure 8

**Table 1. Average Outcome by Market Share of Target Country in FD Market**

	10%	20%	30%	40%	50%	60%	70%	80%	90%
AVE (T,FD)	66.6	70.9	67.0	80.1	84.8	101.8	106.2	126.9	158.5
Pct Chg qD (S,FD)	8.6	19.2	33.0	50.3	74.4	108.4	164.8	272.6	564.2
Pct Chg p (S, FD)	0.3	0.6	1.0	1.4	1.9	2.5	3.3	4.5	6.5
Pct Chg Real Demand (FD)	-2.5	-5.3	-7.6	-11.6	-15.0	-20.3	-24.2	-32.2	-41.1
Pct Chg CPI (FD)	2.6	5.7	8.4	13.5	18.6	27.7	35.9	52.3	83.0

**Table 2. Average Outcome by Market Share of Target Country in INT Market**

	10%	20%	30%	40%	50%	60%	70%	80%	90%
AVE (T,INT)	65.6	68.3	71.2	74.2	78.5	85.0	91.5	102.2	120.6
Pct Chg qD (S,INT)	6.6	14.4	24.2	36.7	53.3	75.9	112.1	175.2	330.9
Pct Chg p (S, INT)	0.2	0.4	0.7	1.0	1.4	1.9	2.5	3.3	4.8
Pct Chg p(S,FD)	0.5	1.0	1.6	2.3	3.1	4.2	5.5	7.4	10.4
Pct Chg q(S,FD)	-1.4	-3.0	-4.7	-6.6	-8.8	-11.6	-14.8	-19.1	-25.8
Pct Chg p(Z)	0.8	1.6	2.6	3.8	5.1	6.9	9.2	12.4	17.8
Pct Chg q(Z)	-2.6	-5.5	-8.5	-11.7	-15.4	-19.9	-24.6	-30.9	-40.0
Pct Chg q (INT)	-4.3	-8.8	-13.5	-18.4	-23.8	-30.1	-36.7	-44.9	-56.0
Pct Chg p (INT)	2.5	5.4	8.8	12.8	17.8	24.6	33.1	46.4	70.4
Pct Chg q(L)	-1.9	-4.0	-6.2	-8.5	-11.2	-14.6	-18.1	-22.9	-30.0
Pct Chg p(K)	-1.9	-4.0	-6.2	-8.5	-11.2	-14.6	-18.1	-22.9	-30.0

**Table 3. Average Outcome by Output Exposure to Sanction**

	10%	20%	30%	40%	50%	60%	70%	80%	90%
Pct Chg q(Z)	-3.1	-6.4	-10.0	-14.0	-18.4	-23.7	-29.9	-37.6	-48.8
Pct Chg q (INT)	-3.4	-7.0	-10.9	-15.2	-20.0	-25.6	-32.3	-40.4	-52.1
Pct Chg q(L)	-4.2	-8.7	-13.5	-18.8	-24.5	-31.1	-38.6	-47.7	-60.1
Pct Chg p(K)	-4.2	-8.7	-13.5	-18.8	-24.5	-31.1	-38.7	-47.7	-60.1